

OPERATION

OPERATOR CONTROLS

The operator's position is at the rear of the machine between the handlebars. The operator should STAND in a position to allow both handlebars to be grasped firmly, which allows sufficient leverage to steer the machine. Operator's controls are shown below.

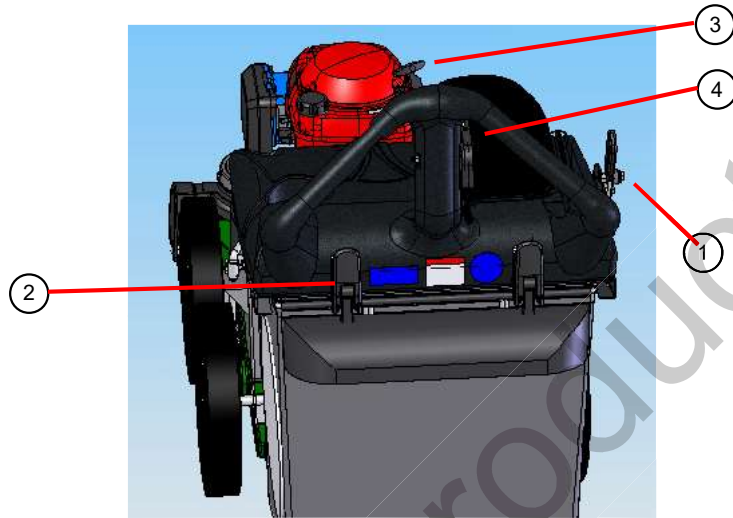

Operator Control Locations

- 1 Nozzle Door Adjuster
- 2 Bag Latch
- 3 Pull Starter
- 4 Throttle Control

STARTING



CHECK engine oil level before operating machine.

1. Place equipment on a level, firm surface that is free of rocks or other debris.
2. Place throttle in CHOKE position.

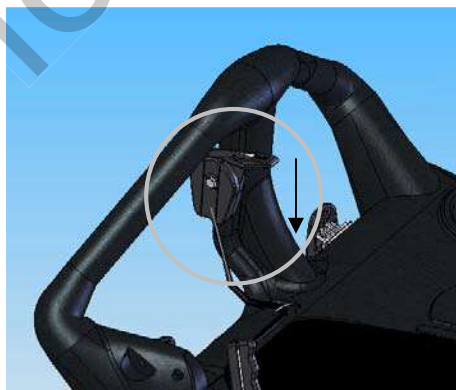

Throttle



WARNING: DO NOT START equipment without the debris bag in place.

- Secure the unit with left hand at the handle then pull starter rope with right hand to start engine.

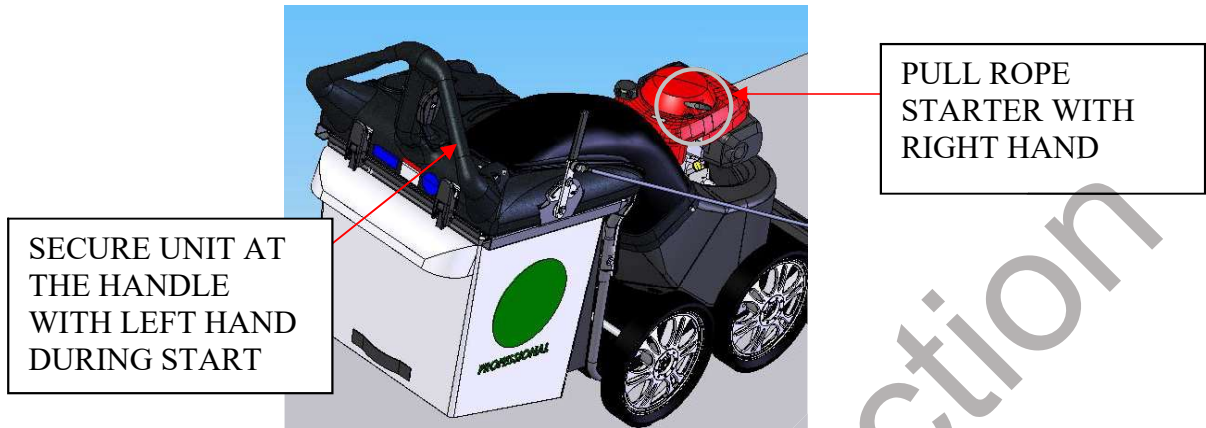

WARNING: PULL STARTER CORD slowly until resistance is felt. Then pull cord rapidly to avoid kickback.

- Move throttle control back to RUN position and allow engine to reach correct operating speed.

VACUUM NOZZLE HEIGHT ADJUSTMENT

FOR MAXIMUM PICKUP: Adjust nozzle height as close to debris as possible, but without blocking airflow into the nozzle.
NOTE: Never bury nozzle into debris. The vacuum nozzle is raised and lowered by turning the crank handle clockwise and counter-clockwise.

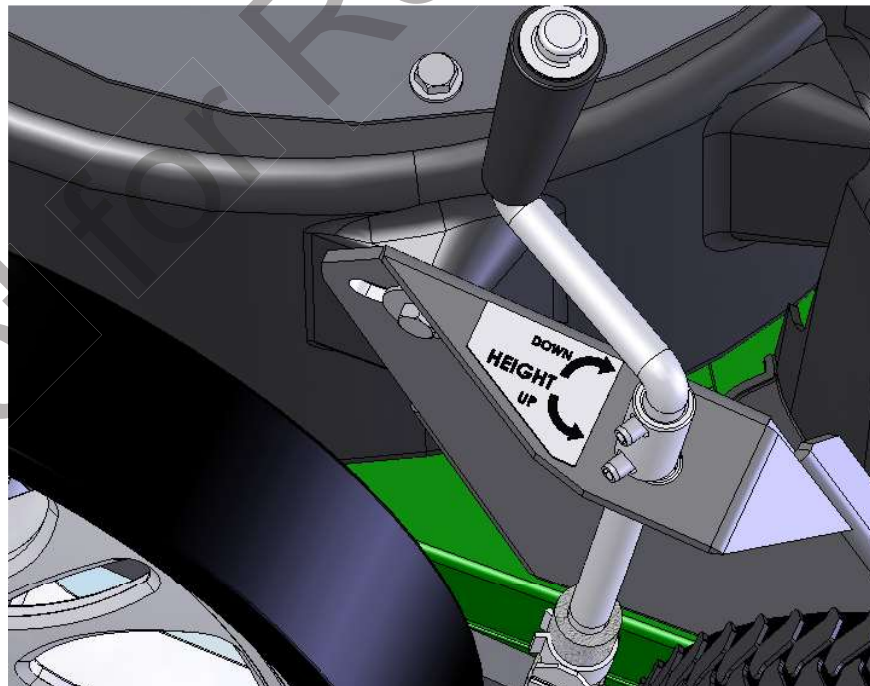

VACUUM NOZZLE DOOR ADJUSTMENT

The vacuum nozzle door adjusts for the maximum performance under various applications.

Nozzle fully opened. This is ideal for turf application

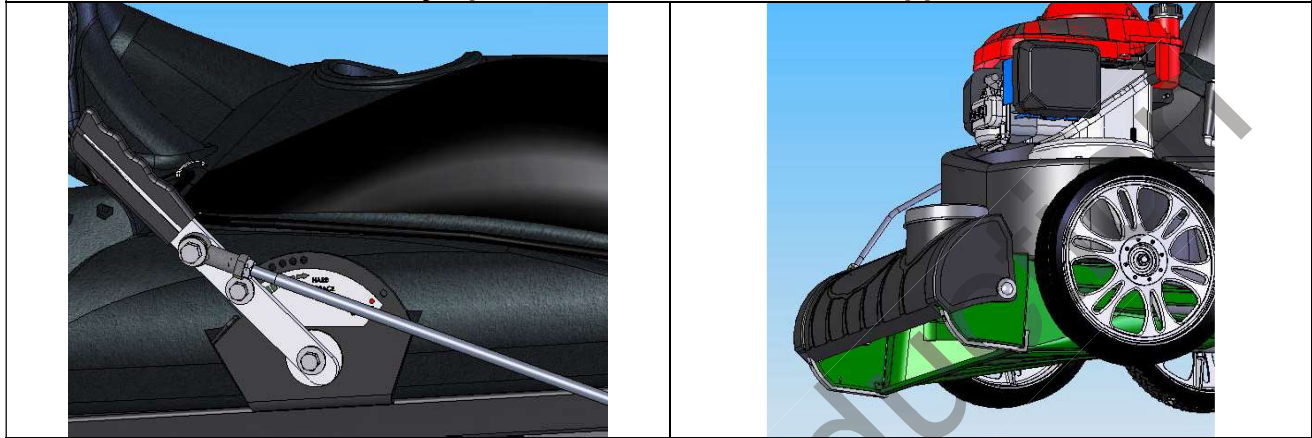

Nozzle half way opened. This is ideal for hard surface application



Nozzle closed for OPTIONAL hose kit. This is ideal TO USE WITH THE HOSE KIT.

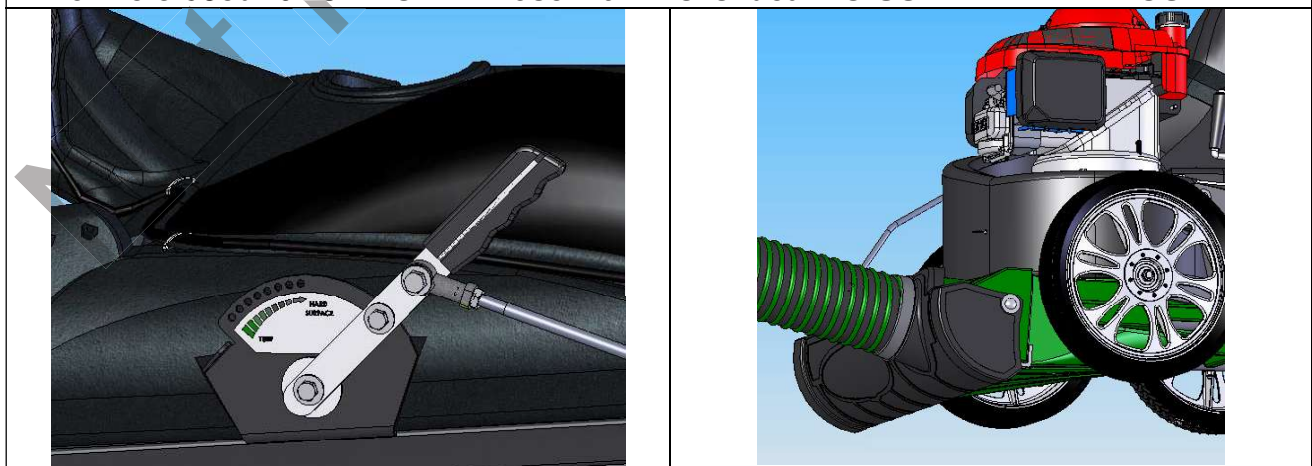



VACUUMING OPERATION

This machine is designed for vacuuming leaves, grass clippings, and other types of organic litter. Debris mixed with cans, bottles, and small amounts of sand can be vacuumed; however, it is not this machine's primary purpose. Vacuuming cans, bottles, and sand will affect the longevity of your machine. In dusty conditions it may be necessary to purchase Felt Bag Kit (P/N 840022).

Do not operate if excessive vibration occurs. If excessive vibration occurs, shut engine off immediately and check for damaged or worn impeller, loose impeller bolt, loose impeller key, loose engine or lodged foreign objects. **Note:** See parts list for proper impeller bolt torque specifications. (See trouble shooting section on page 22).

SHUT DOWN

1. Pull Throttle Control all the way back to the STOP position.

CLEARING A CLOGGED NOZZLE



WARNING: **DISCONNECT** spark plug wire before servicing unit.

1. Shut engine off and wait for impeller to stop completely.
2. Disconnect spark plug wire.
3. Wearing durable gloves, remove clog.



WEAR durable gloves. Clog may contain sharp materials.

4. Reconnect spark plug wire.

DEBRIS BAG

Debris bags are normal replaceable wear items.



WARNING: *Frequently empty debris to prevent bag overloading with more weight than you can lift.*

Bag liners are available for use in various conditions where debris will be vacuumed. (see Bag Liner Options shown on page 1).

DO NOT place bag on or near hot surface, such as engine.



WARNING: *Be sure engine has come to a complete stop before removing or emptying bag!!*

Many vacuums are used where dust is mixed with trash. Your unit can intermittently vacuum in dusty areas. However, following these rules will help maintain your machine's ability to vacuum in dusty conditions:

- Run machine at idle to quarter throttle.
- Machine or pressure-wash debris bag if normal cleaning does not fully clean bag. Bag should be thoroughly dry before use.

Having one or more spare bags (840189) is a good way to reduce down time while dirty bags are being cleaned.

Hint!

Felt Bag (840194) accessory is great when used in dusty conditions.